

OPTIdrill® DH 28GSV / DH 32GSV

Upright drills with Siemens inverter technology and polyamide gearwheels.

With continuously adjustable speed control. Installation of an optional footswitch possible

Facts that impress in terms of quality, performance and price

- ▶ Frequency converter
- ▶ User-friendly membrane keyboard
- ▶ Digital speed display
- ▶ Thread tapping function
- ▶ Smooth action thanks to polished multi-tooth carrier
- ▶ Excellent concentricity thanks to hardened and polished main spindle
- ▶ Low-maintenance, grease-lubricated gearbox
- ▶ Gearbox with PA6 gearwheels
- ▶ Large speed range
- ▶ User-friendly membrane keyboard
- ▶ Heavy, solid cast design
- ▶ Generously dimensioned, height adjustable protective screen with safety switch for greatest possible user protection
- ▶ Adjustable drilling depth stop with millimetre scale
- ▶ Right-handed/left-handed rotation
- ▶ Thread tapping function

- ▶ Machine lamp integrated in drilling head
- ▶ Integrated push-out tool for easy tool changes
- ▶ Drilling table with precision workmanship, diagonal T-slots, circumferential coolant duct
- ▶ Thick walled cast column for high force absorption and stability
- ▶ Solid baseplate, large dimensions und pronounced ribbing on rear
- ▶ Optional footswitch available for toggling between clockwise/ anticlockwise run and for thread tapping (Article no. 3050032)

OPTIdrill DH 32GSV

- ▶ Automatic spindle sleeve feed
- ▶ Coolant system and chip filter in line with Machinery Directive
- ▶ Torque in lowest gear up to 200 Nm

DH 32GSV
Automatic spindle sleeve feed



› Activation by pressure switch in spindle sleeve lever. An electromagnetic clutch provides propulsion. The unit is deactivated using the drilling depth stop or by once again pressing the button in the spindle sleeve lever.

Thermdrill



› Information see page 72



Technical specifications, accessories and dimensions

WITH AND
WITHOUT VARIO



| Model | DH 28GSV | DH 32GSV |
|------------------------------------------------|-------------------------------------|-------------------------|
| Article no. | 3034235 | 3034245 |
| Technical specifications | | |
| Electrical connection | 400 V / 3 Ph ~50 Hz | 400 V / 3 Ph ~50 Hz |
| Motor output | 1.5 kW | 2.2 kW |
| Coolant pump motor | - | 40 W |
| Drilling performance | | |
| Drilling performance in steel (S235JR) | Ø 26 mm | Ø 30 mm |
| Continuous drilling performance steel (S235JR) | Ø 23 mm | Ø 26 mm |
| Thread tapping steel (S235JR) | M 16 x 2 mm | M 16 x 2 mm |
| Spindle | | |
| Spindle sleeve stroke | 127 mm | 125 mm |
| Spindle seat | MT 3 | MT 4 |
| Throat | 260 mm | 285 mm |
| Automatic spindle sleeve feed | - | 2 speeds: 0.05 / 0.1 mm |
| Speeds | | |
| Spindle speeds | 45 - 3 200 rpm | 40 - 3 000 rpm |
| Number of speeds | 4 speeds, electronically controlled | |
| Drilling table | | |
| Drilling table workspace L x W | 376 x 394 mm | 400 x 420 mm |
| T-slot size | 14 mm, diagonal | 14 mm, diagonal |
| Drilling table load bearing capacity | 150 kg | 200 kg |
| Rotating drilling table | 360° | 360° |
| Clearance spindle - drilling table | max. 875 mm | max. 820 mm |
| Machine base | | |
| Machine base work area L x W | 350 x 356 mm | 420 x 395 mm |
| T-slot size / spacing / count | 14 mm / 120 mm / 2 | 14 mm / 150 mm / 2 |
| Distance spindle - machine base | max. 1 285 mm | max. 1 270 mm |
| Dimensions | | |
| Column diameter | Ø 92 mm | Ø 115 mm |
| Length x width x height | 690 x 375 x 2 080 mm | 820 x 450 x 2 230 mm |
| Overall weight | 175 kg | 304 kg |

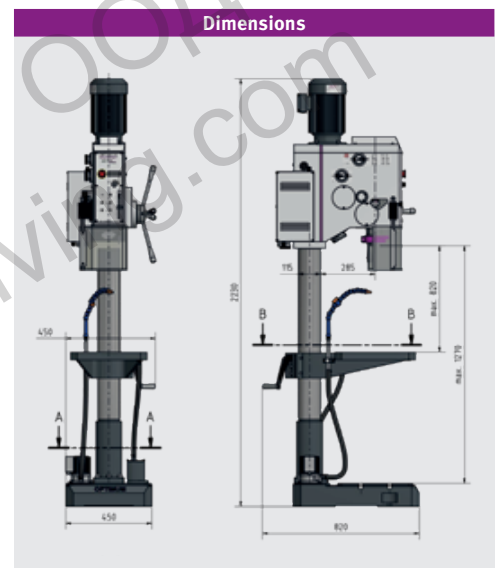
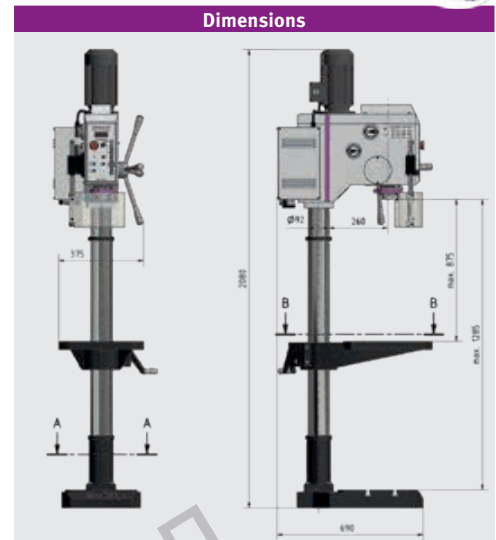

Scope of supply

> Morse taper MK

| Accessories | Article no. |
|-----------------------------------------------|-------------|
| Assortment of clamping tools size 12, 58-part | 3352017 |
| Quick clamping drill chuck 1 - 8 mm; B16 | 3050608 |
| Quick clamping drill chuck 1 - 10 mm; B16 | 3050610 |
| Quick clamping drill chuck 1 - 13 mm; B16 | 3050623 |
| Quick clamping drill chuck 1 - 16 mm; B16 | 3050626 |
| Twist drill bits HSS-CO 5%, 25 parts | 3201010 |
| Twist drill bits HSS-CO 5%, 51 parts | 3201020 |
| Twist drill bits HSS-CO 5%, 41 parts | 3201021 |
| Thermdrill MT 2 | 3060005 |
| Foot switch | 3050032 |

Functions: Right-handed/left-handed rotation for thread tapping

> More „Accessories for drills“ from page 64



| Machine vices | Article no. |
|---------------|-------------|
| BMS 120 | 3000012 |
| BSI 100 | 3000210 |
| BSI 140 | 3000214 |
| BSI-Q 100 | 3000230 |
| BSI-Q 140 | 3000234 |

> Information on the vises on page 71

| Accessories DH 28GSV | Article no. |
|------------------------------------|-------------|
| Direct quick release chuck 1-16 mm | 3050573 |
| Morse taper MT 3/B16 | 3050660 |
| Reduction sleeve MT 3 - MT 2 | 3050663 |
| Twist drill HSS / MT 3 | 3051003 |
| Universal coolant unit | 3352002 |

| Accessories DH 32GSV | Article no. |
|------------------------------------|-------------|
| Direct quick release chuck 1-16 mm | 3050574 |
| Morse taper MT 4/B16 | 3050661 |
| Reduction sleeve MT 4 - MT 3 | 3050664 |
| Reduction sleeve MT 4 - MT 2 | 3050665 |